

065

ZK-065 | Konik Dişli Redüktör

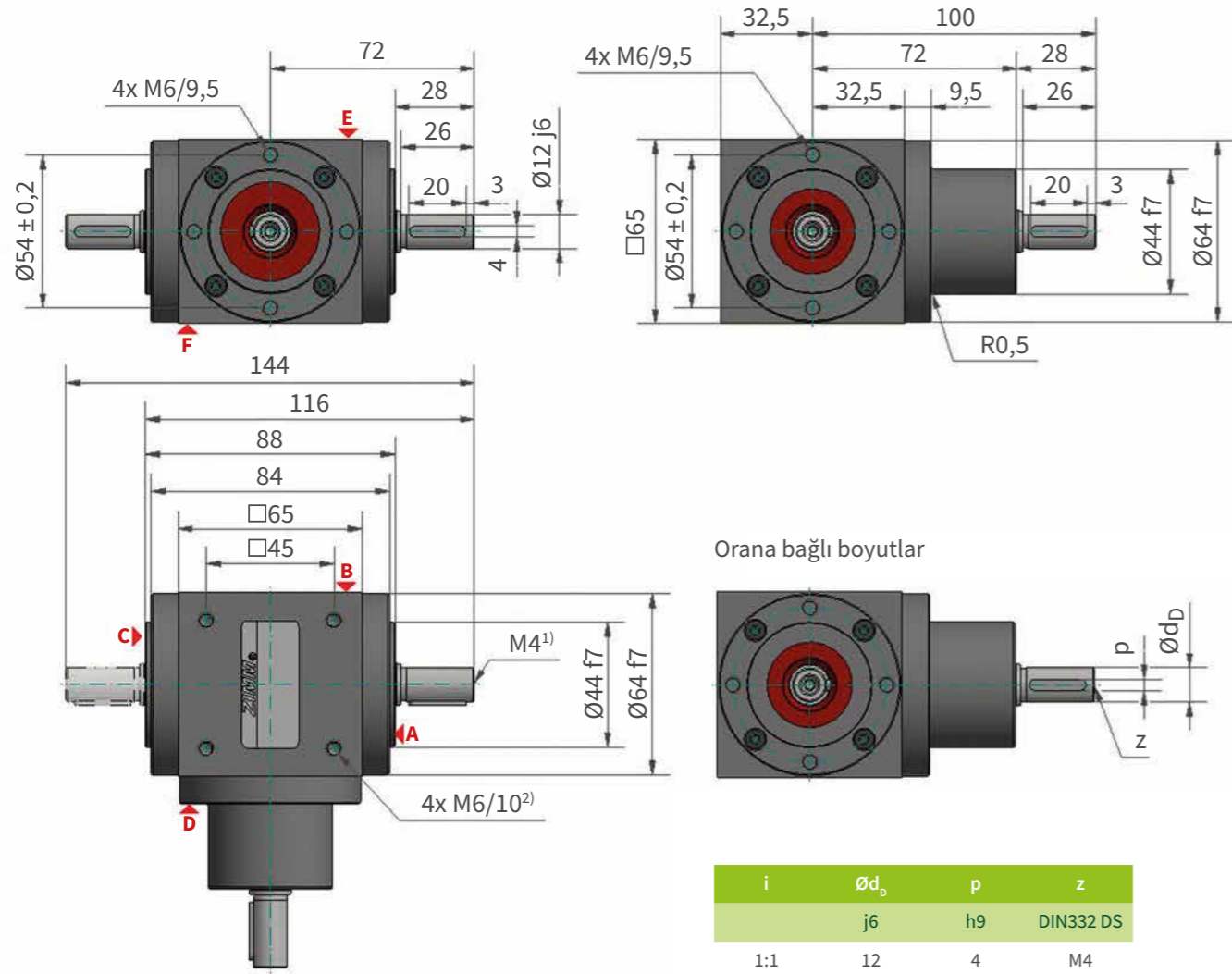

Orana bağlı boyutlar

i	Ødb	p	z
	j6	h9	DIN332 DS
1:1	12	4	M4
2:1	12	4	M4
3:1	12	4	M4

1) DIN 332 DS'ye göre mil merkezlemeleri
2) M6 sabitleme delikleri, gövde tarafı B, E ve F

Torklar ve yanal kuvvetler

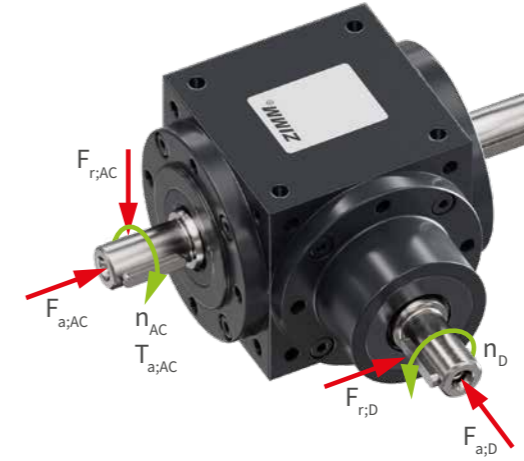

i	nd	nAC	Pa	P _t ¹⁾	T _{a,AC}	F _{a,D}	F _{r,D}	F _{a,AC}	F _{r,AC}
nd : nAC	min ⁻¹	min ⁻¹	kW	kW	Nm	N	N	N	N
1:1	50	50	0,09	1,3	18,00	420	570	700	950
	100	100	0,19	1,3	18,00	350	480	550	800
	250	250	0,46	1,3	17,50	270	370	450	700
	500	500	0,92	1,3	17,50	230	320	400	550
	750	750	1,37	1,3	17,50	200	280	310	480
	1000	1000	1,78	1,3	17,00	180	260	240	420
	1500	1500	2,36	1,3	15,00	160	230	200	390
	2000	2000	2,83	1,3	13,50	150	210	190	370
	2400	2400	3,27	1,3	13,00	140	200	170	350
3000	3000	3,77	1,3	12,00	130	180	160	340	

i	nd	nAC	Pa	P _t ¹⁾	T _{a,AC}	F _{a,D}	F _{r,D}	F _{a,AC}	F _{r,AC}
nd : nAC	min ⁻¹	min ⁻¹	kW	kW	Nm	N	N	N	N
2:1	50	25	0,04	1,3	16,50	420	570	700	950
	100	50	0,09	1,3	16,50	350	480	550	800
	250	125	0,22	1,3	16,50	270	370	450	700
	500	250	0,41	1,3	15,50	230	320	400	550
	750	375	0,59	1,3	15,00	200	280	310	480
	1000	500	0,79	1,3	15,00	180	260	240	420
	1500	750	1,14	1,3	14,50	160	230	200	390
	2000	1000	1,52	1,3	14,50	150	210	190	370
	2400	1200	1,82	1,3	14,50	140	200	170	350
3000	1500	2,28	1,3	14,50	130	180	160	340	

i	nd	nAC	Pa	P _t ¹⁾	T _{a,AC}	F _{a,D}	F _{r,D}	F _{a,AC}	F _{r,AC}
nd : nAC	min ⁻¹	min ⁻¹	kW	kW	Nm	N	N	N	N
3:1	50	17	0,02	1,3	14,00	420	570	700	950
	100	33	0,05	1,3	14,00	350	480	550	800
	250	83	0,12	1,3	13,50	270	370	450	700
	500	167	0,24	1,3	13,50	230	320	400	550
	750	250	0,34	1,3	13,00	200	280	310	480
	1000	333	0,45	1,3	13,00	180	260	240	420
	1500	500	0,68	1,3	13,00	160	230	200	390
	2000	667	0,87	1,3	12,50	150	210	190	370
	2400	800	1,01	1,3	12,00	140	200	170	350
3000	1000	1,20	1,3	11,50	130	180	160	340	

1) S1 çalışma koşulunda, temiz iç ortam kurulumunda ve 20°C ortam sıcaklığında