

# 140

ZK-140 | Konik Dişli Redüktör

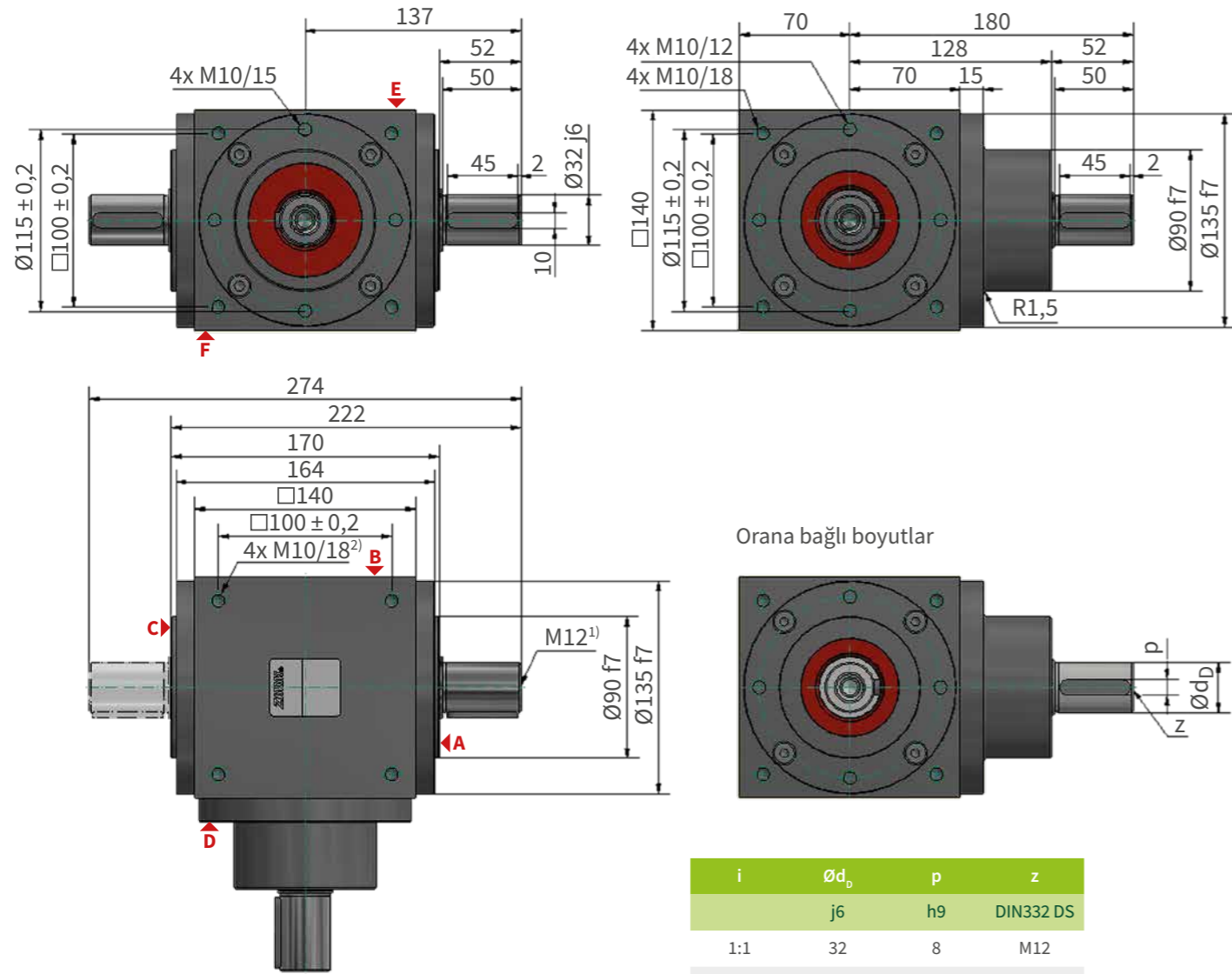

i	Ød <sub>D</sub>	p	z
	j6	h9	DIN332 DS
1:1	32	8	M12
2:1	32	8	M12
3:1	28	7	M10

1) DIN 332 DS'ye göre mil merkezlemeleri  
2) M10 sabitleme delikleri, tüm 6 gövde tarafında

## Torklar ve yanal kuvvetler

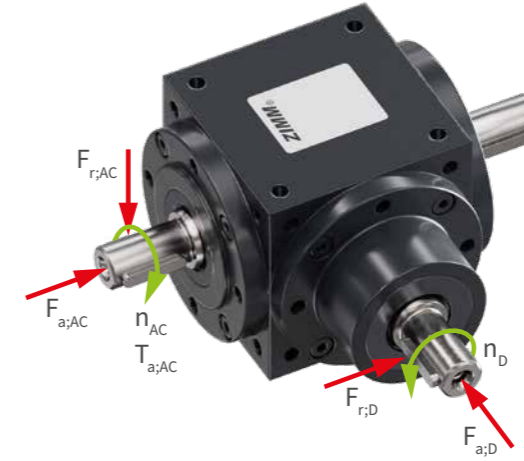

i	n <sub>D</sub>	n <sub>AC</sub>	P <sub>a</sub>	P <sub>t</sub> <sup>1)</sup>	T <sub>a,AC</sub>	F <sub>a,D</sub>	F <sub>r,D</sub>	F <sub>a,AC</sub>	F <sub>r,AC</sub>
n <sub>D</sub> : n <sub>AC</sub>	min <sup>-1</sup>	min <sup>-1</sup>	kW	kW	Nm	N	N	N	N
1:1	50	50	1,05	5,4	200	1550	2100	2550	3900
	100	100	2,09	5,4	200	1300	1900	2100	3100
	250	250	4,97	5,4	190	1050	1450	1600	2600
	500	500	9,69	5,4	185	850	1100	1300	2050
	750	750	12,96	5,4	165	700	950	1200	1850
	1000	1000	16,02	5,4	153	610	870	1100	1700
	1500	1500	21,52	5,4	137	490	790	1050	1550
	2000	2000	26,18	5,4	125	450	740	1000	1450
2400	2400	29,65	5,4	118	430	720	950	1350	
3000	3000	34,55	5,4	110	410	680	900	1300	

i	n <sub>D</sub>	n <sub>AC</sub>	P <sub>a</sub>	P <sub>t</sub> <sup>1)</sup>	T <sub>a,AC</sub>	F <sub>a,D</sub>	F <sub>r,D</sub>	F <sub>a,AC</sub>	F <sub>r,AC</sub>
n <sub>D</sub> : n <sub>AC</sub>	min <sup>-1</sup>	min <sup>-1</sup>	kW	kW	Nm	N	N	N	N
2:1	50	25	0,52	5,4	200	1550	2100	2550	3900
	100	50	1,05	5,4	200	1300	1900	2100	3100
	250	125	2,49	5,4	190	1050	1450	1600	2600
	500	250	4,71	5,4	180	850	1100	1300	2050
	750	375	6,36	5,4	162	700	950	1200	1850
	1000	500	7,85	5,4	150	610	870	1100	1700
	1500	750	10,52	5,4	134	490	790	1050	1550
	2000	1000	12,77	5,4	122	450	740	1000	1450
2400	1200	14,45	5,4	115	430	720	950	1350	
3000	1500	16,49	5,4	105	410	680	900	1300	

i	n <sub>D</sub>	n <sub>AC</sub>	P <sub>a</sub>	P <sub>t</sub> <sup>1)</sup>	T <sub>a,AC</sub>	F <sub>a,D</sub>	F <sub>r,D</sub>	F <sub>a,AC</sub>	F <sub>r,AC</sub>
n <sub>D</sub> : n <sub>AC</sub>	min <sup>-1</sup>	min <sup>-1</sup>	kW	kW	Nm	N	N	N	N
3:1	50	17	0,31	5,4	175	1550	2100	2550	3900
	100	33	0,60	5,4	173	1300	1900	2100	3100
	250	83	1,48	5,4	170	1050	1450	1600	2600
	500	167	2,79	5,4	160	850	1100	1300	2050
	750	250	3,93	5,4	150	700	950	1200	1850
	1000	333	5,06	5,4	145	610	870	1100	1700
	1500	500	7,17	5,4	137	490	790	1050	1550
	2000	667	9,08	5,4	130	450	740	1000	1450
2400	800	10,22	5,4	122	430	720	950	1350	
3000	1000	11,94	5,4	114	410	680	900	1300	

1) S1 çalışma koşulunda, temiz iç ortam kurulumunda ve 20°C ortam sıcaklığında