

Instruction manual

Screw jack

Installation – Operation – Maintenance – Inspection

ZE-5 – ZE-1000

ZE-H-35 – ZE-H-200

Z-5 – Z-1000

GSZ-2 – GSZ-150

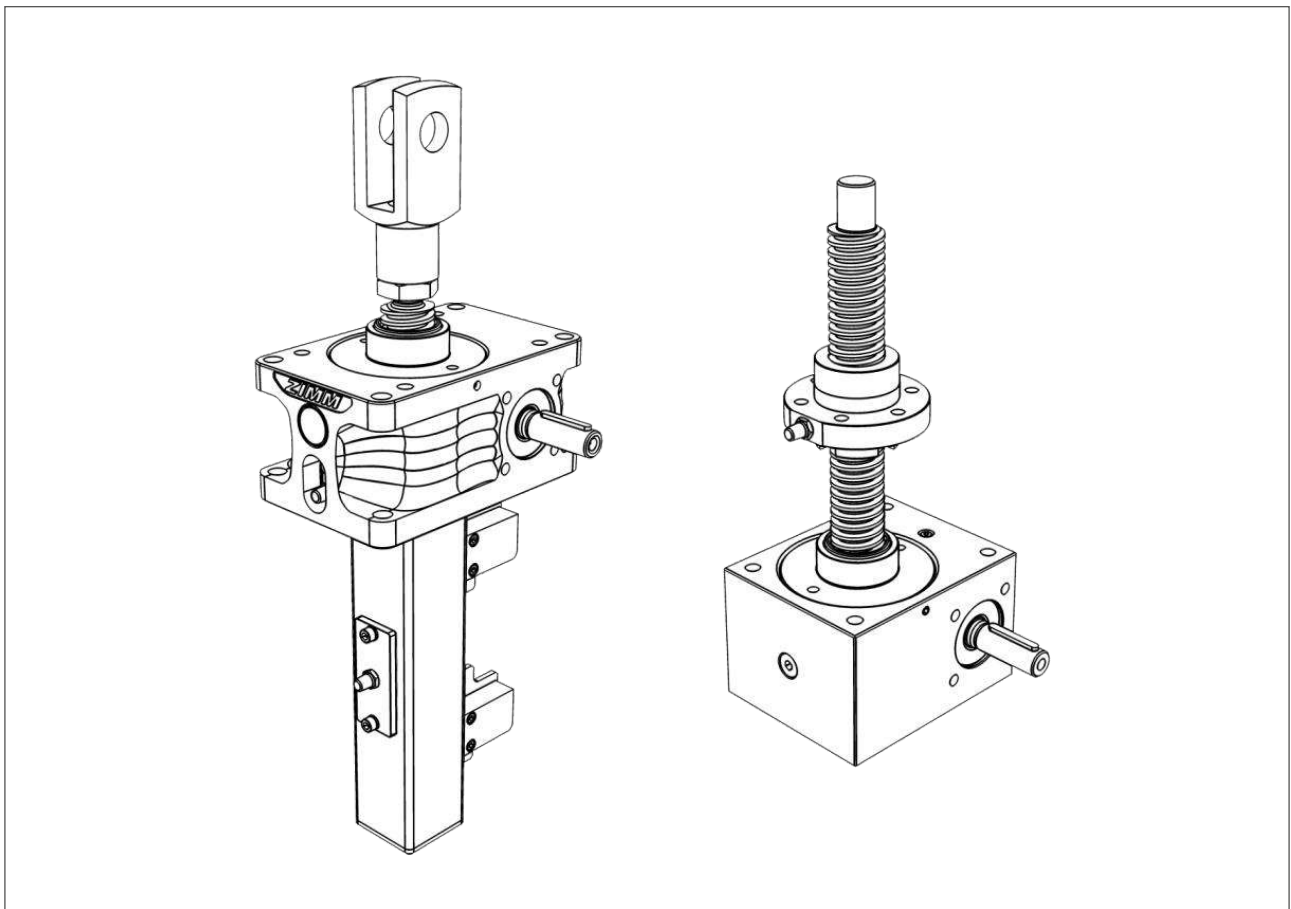

Translation of the original

Instruction manual Publisher

ZIMM GmbH

Millennium Park 3

6890 Lustenau/Austria

Phone: +43 (0) 5577 806-0

Fax: +43 (0) 5577 806-8

E-Mail: info@zimm.com

Internet: <https://www.zimm.com>

Author

ZIMM GmbH

Date of issue

2024-06

Version

2.03

Copyright

© ZIMM GmbH

Subject to technical and content changes.

Legal information

The contents of these operating instructions are confidential and intended for operating personnel only.

Reproduction or passing on and transfer of these operating instructions to third parties is prohibited and will result in liability for damages.

ZIMM GmbH accepts no liability for damage caused by non-compliance with these operating instructions.

Table of contents

1	About this document	4
1.1	Handling these operating instructions	4
1.2	Symbols and labeling	4
2	Security	5
2.1	Intended use	5
2.2	Obligations of the operator	5
3	Scope of supply	6
4	Product description	6
4.1	Overview	6
4.2	Nameplate	7
4.3	Versions / Variants	8
4.4	Grease nipple	9
5	Transportation and storage	10
5.1	Transportation	10
5.2	Storage	12
6	Assembly	13
6.1	Installing screw jacks and bevel gear drives	14
6.2	Fitting couplings and connecting shafts	16
6.3	Fitting the motor	17
6.4	Connecting electrical components	18
6.5	Test run	21
6.6	Correct alignment	22
6.7	Commissioning	23
6.8	Run-in phase	24
7	Operation and maintenance	25
7.1	Inspection	25
7.2	Lubrication	27
7.3	Troubleshooting	33
8	Decommissioning and recommissioning	35
9	Repair and replacement	35
10	Waste disposal	35
11	Declaration of incorporation	36
12	Annex: Inspection log	37





1 About this document

1.1 How to use these operating instructions

These operating instructions are part of the ZIMM Screw jack.

- Read the operating instructions carefully before use.
- Keep the operating instructions for the entire service life.
- Make the operating instructions accessible to operating and maintenance personnel at all times.
- Pass the operating instructions on to any subsequent owner or user.
- Update the operating instructions with every supplement received from the manufacturer.

1.2 Symbols and markings

Icon	Meaning
 DANGER	Dangers for persons. Disregard will lead to death or serious injuries.
 WARNING	Dangers to persons. Non-compliance can lead to death or serious injury.
 CAUTION	Dangers to persons. Non-compliance can lead to minor injuries.
 CAUTION	Information to prevent damage to property.
 NOTE	Tips for understanding or optimizing work processes.
✓	Prerequisite for an instruction manual.
→	One-step call to action.
1. ... 2. ...	Multi-step instructions. → Observe the sequence.

Tab. 1: Symbols and labels

2 Security

The ZIMM Screw jack is built according to the state of the art and recognized safety regulations. Nevertheless, danger to life and limb of the user or third parties or damage to the ZIMM Screw jack and other property may occur during use.

- ZIMM Screw jacks may only be used if they are in perfect technical condition and in accordance with the operating instructions.
- Have any defects rectified without delay.
- Do not make any unauthorized modifications to the ZIMM Screw jack.
- Only use original spare parts from ZIMM GmbH.

2.1 Intended use

The ZIMM Screw jack is only suitable for lifting, lowering, tilting and feed movements within the designated lifting capacity ranges.

The user is responsible for the respective application.

The lifting systems may only be operated within the limits described in our catalogs and brochures and within the permissible limit values.

For compliance with the Electromagnetic Compatibility Act, the ZIMM Screw jacks may only be used in industrial applications as defined in EN 50 081-2.

Any other use is considered improper use.

In cases of doubt, the use of the ZIMM Screw jack must be clarified in advance with ZIMM GmbH.

2.2 Obligations of the operator

- Ensure that the ZIMM Screw jack is only operated and maintained in accordance with these operating instructions and the nationally applicable regulations and guidelines.
- Ensure that the staff
 - is authorized to operate the ZIMM Screw jack,
 - is trained and qualified for the respective activity,
 - has read and understood these operating instructions,
 - knows the relevant safety regulations and
 - wears personal protective equipment (protective gloves, hard hat and safety shoes).

3 Scope of supply

The ZIMM Screw jack is delivered in adequately secured packaging to prevent possible shipping damage.

The following parts are included in the scope of supply of the ZIMM Screw jack:

- ZIMM Screw jack
- These operating instructions
- Other parts according to delivery bill

4 Product description

4.1 Overview

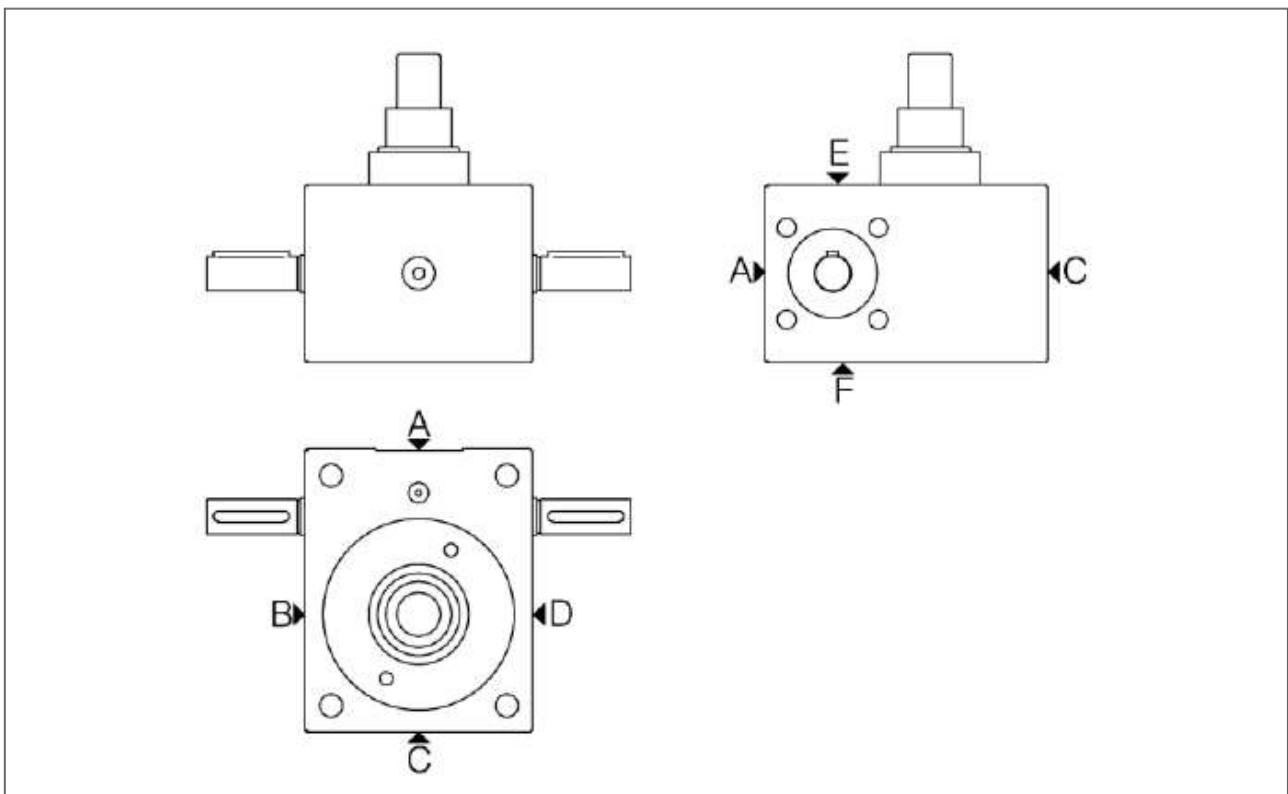

Fig. 1: Overview of ZIMM Screw jacks

A to F: sides of the ZIMM Screw jack.

4.2 Type plate

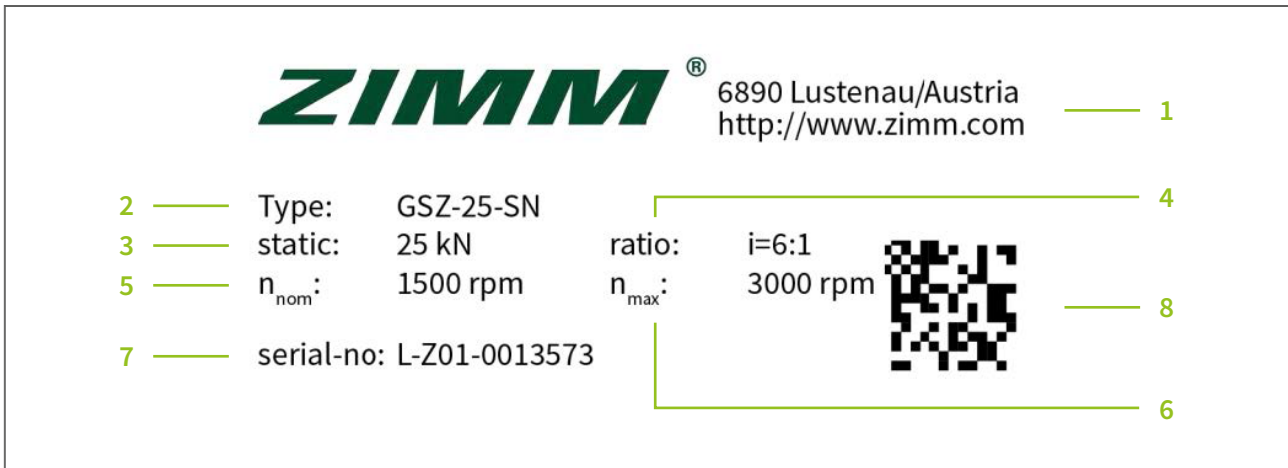

Fig. 2: Example of a type plate

- | | | | |
|---|--|---|--------------------------------------|
| 1 | Contact details ZIMM | 5 | Rated speed |
| 2 | Type designation | 6 | max. speed |
| 3 | Maximum static load gearbox
(spindle etc. not included) | 7 | Serial number |
| 4 | Gear ratio | 8 | Serial number
as Data Matrix Code |

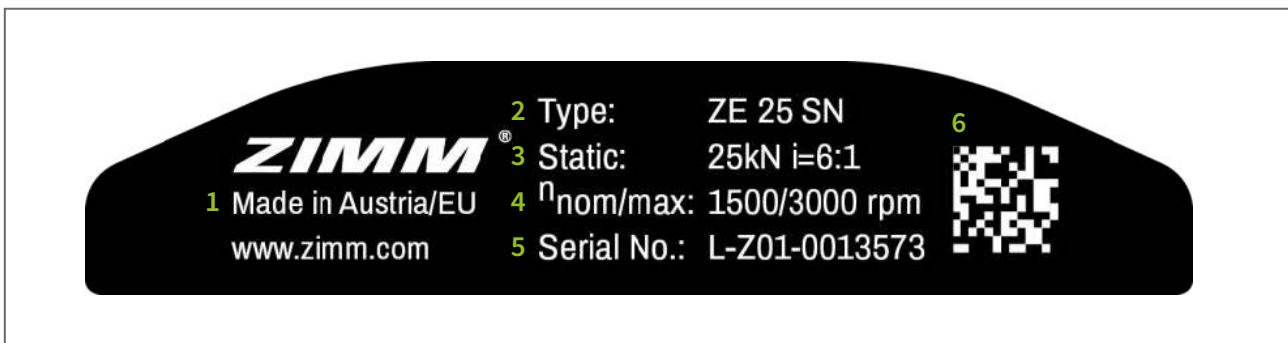
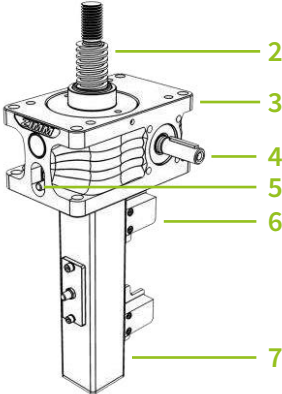
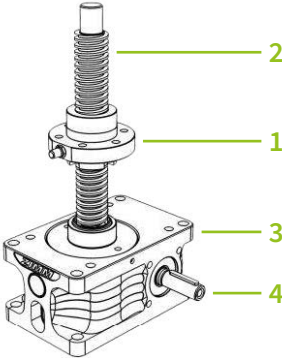

Fig. 3: Example of a type plate

- | | | | |
|---|--|---|--------------------------------------|
| 1 | Contact details ZIMM | 4 | Rated speed / max. speed |
| 2 | Type designation | 5 | Serial number |
| 3 | Maximum static load gearbox
(spindle etc. not included)
and Gear ratio | 6 | Serial number
as Data Matrix Code |

4.3 Versions / Variants

Variant	Standing (S version)	Rotating (R version)
ZE, ZE-H and Z series, Standard with trapezoidal screw jack TR		

- | | | | |
|---|------------------------------|---|---------------------|
| 1 | Travelling nut | 5 | Spindle lubrication |
| 2 | Trapezoidal screw spindle TR | 6 | Limit switch |
| 3 | Enclosure ZE series | 7 | Protective tube |
| 4 | Drive shaft | | |

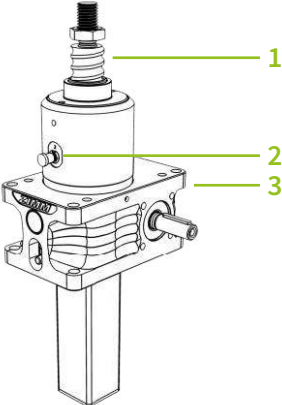
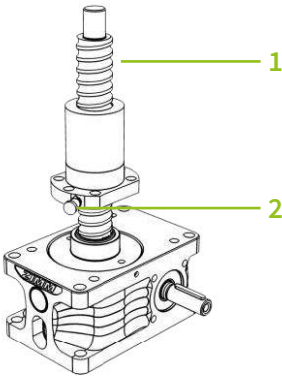
Variant	Standing (S version)	Rotating (R version)
ZE, ZE-H and Z series, with ball screw drive KGT		

- | | |
|---|--------------------------|
| 1 | Ball screw spindle KGT |
| 2 | Spindle lubrication |
| 3 | Housing bevel gear drive |

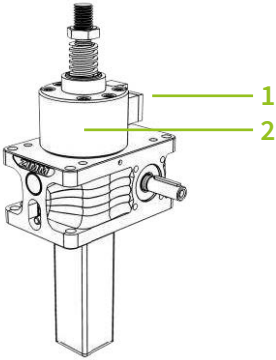
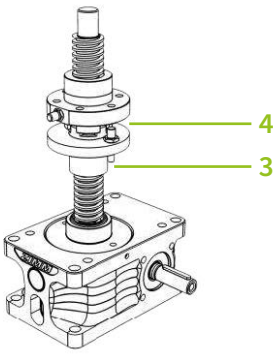
Variant	Standing (S version)	Rotating (R version)
ZE, ZE-H and Z series, with safety catch nut SIFA		

- 1 Electrical or optical Monitoring
- 2 Gearbox with integrated Safety catch nut SIFA

- 3 Safety catch nut SIFA
- 4 Electrical Monitoring

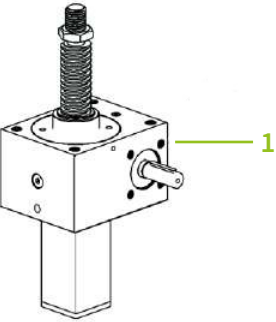
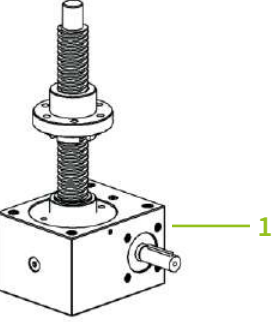
Variant	Standing (S version)	Rotating (R version)
GSZ series, standard KGT and SIFA variants are also possible, similar to the ZE series (not shown here)		

- 1 Housing GSZ series

4.4 Grease nipple

ZIMM Screw jacks of the S and R versions have grease nipples that allow easy and clean lubrication of the spindle (part from the flanged nut FM).

NOTE

For optimum lubrication, use an automatic lubricator (e.g. Z-LUB).

5 Transportation and storage

5.1 Transportation



WARNING

Falling load!

Falling loads can lead to serious injuries.

- Ensure that the lifting slings used are securely fastened and cannot slip.
- Do not stay under the suspended load.
- Wear personal protective equipment.



CAUTION

High weight!

Injuries to components weighing 25 kg or more.

- Transport heavy ZIMM Screw jacks properly (max. 25 kg per person).



CAUTION

Damage to the ZIMM Screw jack!

- Check the packaging for damage on receipt.
- Do not drop ZIMM Screw jacks and do not subject them to impacts.
- Use suitable lifting gear if necessary.

Bending the spindle!

- Handle long and thin spindles with particular care to avoid bending.

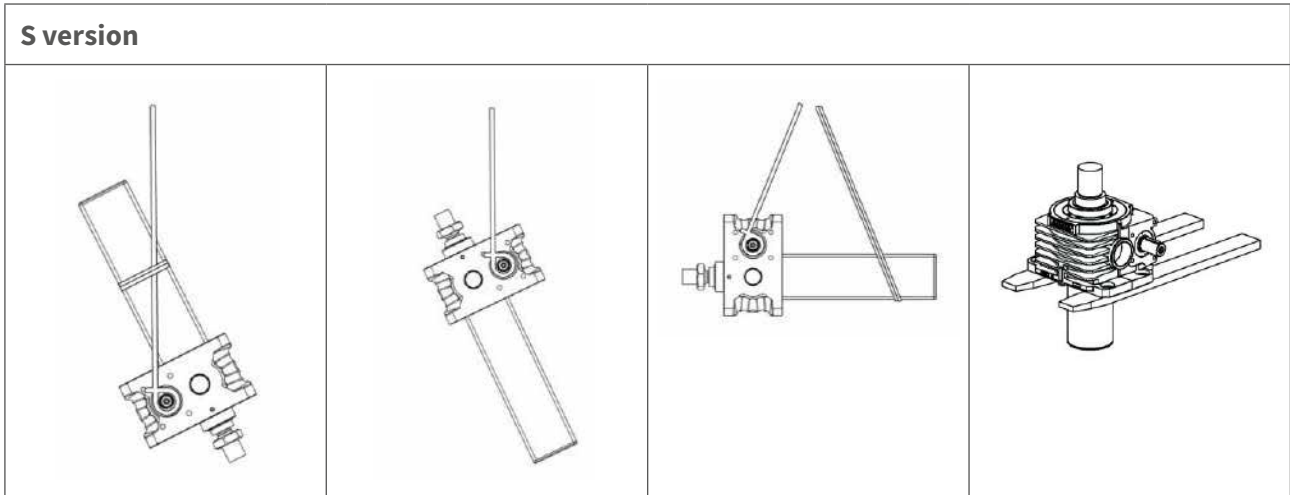

Fig. 4: Examples of transportation for the S version

- ➔ When lifting with the crane, attach the lifting slings to suitable lifting points.
- ➔ During transportation, distribute the weight of the ZIMM Screw jack as evenly as possible over all holding points.

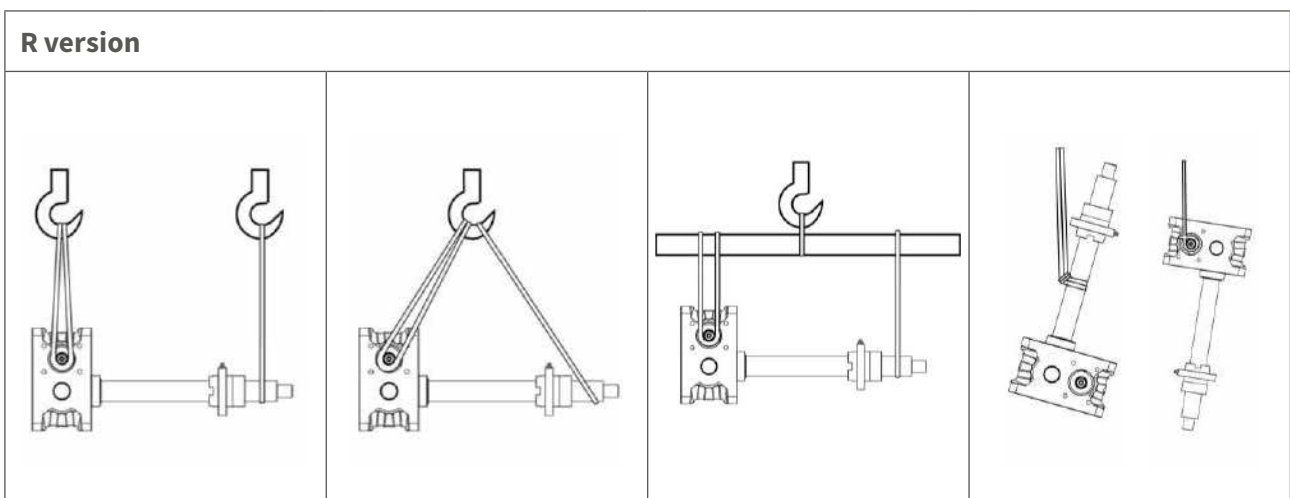
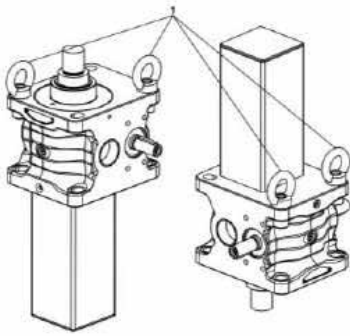

Fig. 5: Examples of transportation for the R version

Transport fastening



Ring bolts or ring nuts can be attached to the gearbox for secure hanging.

Fig. 6: Ring bolts (1) or ring nuts (not included in the scope of supply)

5.2 Storage

CAUTION

Incorrect storage!

Damage due to corrosion.

- Only store in closed and dry rooms.
- Do not store for more than a brief period in areas that although roofed still allow free circulation of air from outside
- Carry out commissioning no later than 1 year after delivery (delivery date from ZIMM is decisive).

→ For other storage conditions and storage times: Please consult ZIMM GmbH.

6 Assembly



WARNING

Risk of shearing, pinching and crushing!

- Switch off the entire system and secure it against being switched on again.
- Work may only be carried out by trained specialists.
- Do not remove existing covers.
- Wear personal protective equipment.

Sharp edges!

Cut injuries.

- Wear protective gloves.



CAUTION

High forces are generated!

Material damage to the overall system and ZIMM Screw jack.

- Ensure that the following installation conditions are observed:
 - Limit switches are not overridden.
 - Tolerance parallelism and angularity: see chapter 6.1, page 14
 - The direction of rotation and movement of all components is correct.
 - Safety distance between moving and fixed components is maintained.

Lack of self-locking!

Material damage to the overall system and ZIMM Screw jack due to lack of self-locking on screw with ball screw drive KGT.

- Provide spring-applied brake FDB or brake motor.
- For S version, provide AS anti-rotation device or VS torsional protection.
- Ensure that the spindle or nut does not unscrew during installation, particularly in the case of vertical installation.

The system will run on!

Material damage to the overall system and ZIMM Screw jack due to overrun.

- The run-on travel may increase after the running-in phase.
- Provide spring-applied brake FDB or brake motor if required.

! NOTE

Additional hazards may arise during installation and operation of the entire system.

- Observe regional regulations and implement necessary measures (e.g. risk assessment).
- Document all additional hazards in the overall system documentation.

6.1 Installing screw jacks and bevel gear drives

- ✓ Ensure that the spindle of the ZIMM Screw Jack or on the ZIMM Screw Jack cannot be exposed to lateral loads.

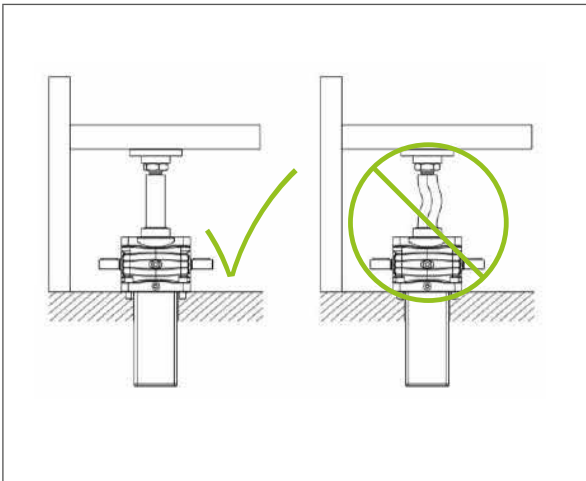

Fig. 7: Side forces on the spindle are not permissible.

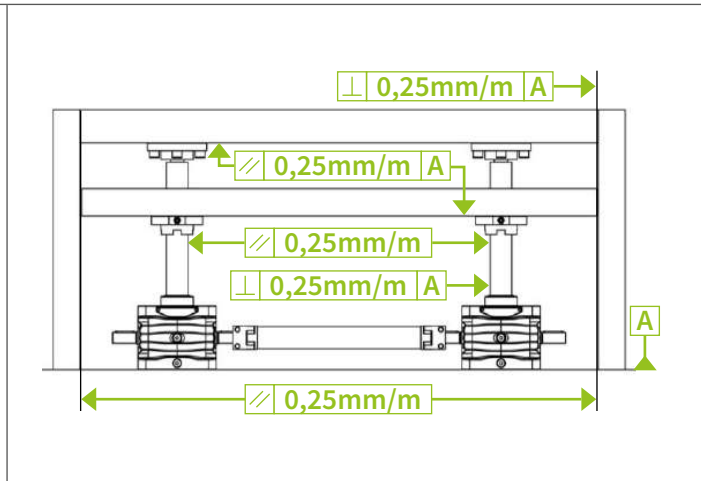

Fig. 8: Installation accuracy: parallelism and perpendicularity

1. Set up the ZIMM Screw jack and ensure straight alignment for the spindle attachments (e.g. with a precision machine spirit level).
2. Mount the ZIMM Screw jack with screws, tighten the mounting screws.
3. Fit the screws for sizes 50, 100 and 150 of the ZE and Z series to the elongated holes using washers (e.g. to DIN 1441). Fit the spindle head (see Fig. 9), fix the locking screws with threadlocker (e.g. Loctite), fit the lock nut (up to size 100).

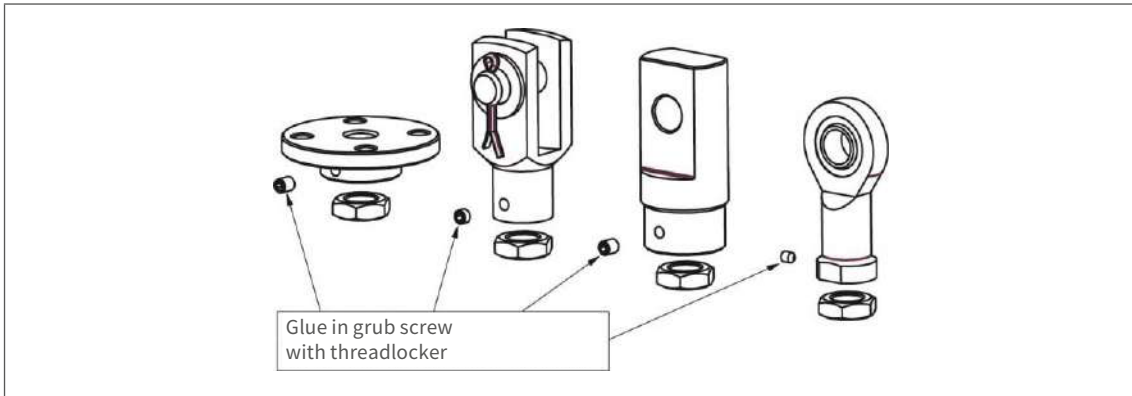

Fig. 9: Fix parts such as Fixing flange, Forked end, Pivot bearing end, Rod end and ball joint heads after setting the position.

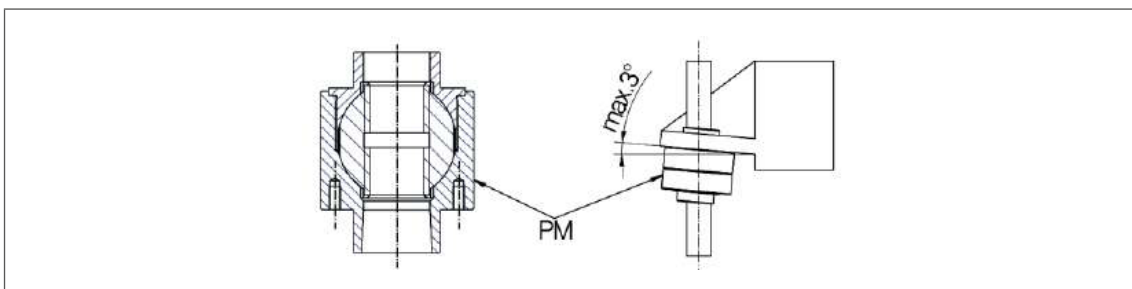

Fig. 10: Exception: Maximum angle of inclination of the pendulum nut (PM) is 3°, mount all other nuts at right angles.

Bevel gear drive The direction of rotation can be changed by turning the T-Version

Fig. 11: T-Version (Bevel gear drive)

→ Ensure correct direction of rotation during installation.

Bellows

If the bellows have not already been fitted at the factory, make sure that any existing venting screens are located at the top of the bellows end of the bellows (due to gravity, the lower pleats open last and close first; this makes venting more difficult).

6.2 Fitting couplings and connecting shafts

- ✓ The screw jacks to be connected must have been fully installed.
- ✓ The bevel gear drives must be installed where appropriate.

CAUTION

Moving parts!

Injuries caused by rotating parts.

→ Switch off the entire system and secure it against being switched on again.

1. Place the connecting shaft on the shaft extensions (ZIMM Screw jack or Bevel gear drive). Ensure that the gearboxes are correctly leveled.
2. Fix the coupling half shells with mounting screws with the following tightening torques:

Connecting shaft	Coupling	Tightening torque
VWZ-30	KUZ-KK-16	4 Nm
VWZ-40	KUZ-KK-24	8 Nm
VWZ-60	KUZ-KK-32	15 Nm
VWZ-60V	KUZ-KK-35	35 Nm
VWZ-80	KUZ-KK-45	70 Nm
VWZ-100	KUZ-KK-60	120 Nm

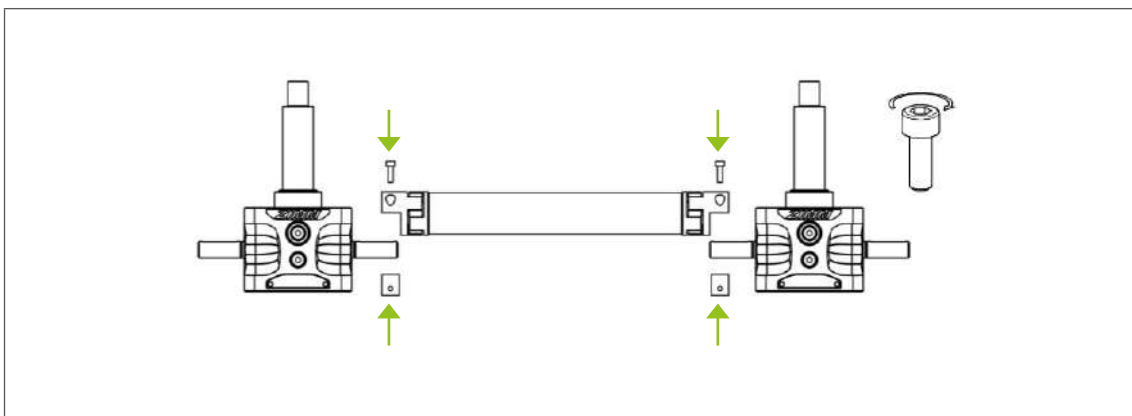

Fig. 12: Mounting the connecting shafts



CAUTION

Axial joining force!

Damage to the roller bearings, circlips, etc.

- Mount the parts to be fitted using a suitable device.
- Avoid knocks or impacts on shaft extensions.

3. Fit KUZ couplings (couplings without coupling half shells) onto shaft extensions.
Fix the grub screw with the following tightening torques:

Size KUZ-..	Grub screw	Tightening torque
09, (14)	M4	1,5 Nm
24, 28	M5	2,0 Nm
14, 19, 38	M6	4,8 Nm
45, 55, 60	M8	10 Nm
70, 75, 90	M10	17 Nm

To increase security, the grub screw can be secured with „medium-strength“ threadlocker.

6.3 Fitting the motor

- ✓ ZIMM Screw jack is installed.



CAUTION

Moving parts!

Injuries caused by rotating parts.

- Switch off the entire system and secure it against being switched on again.

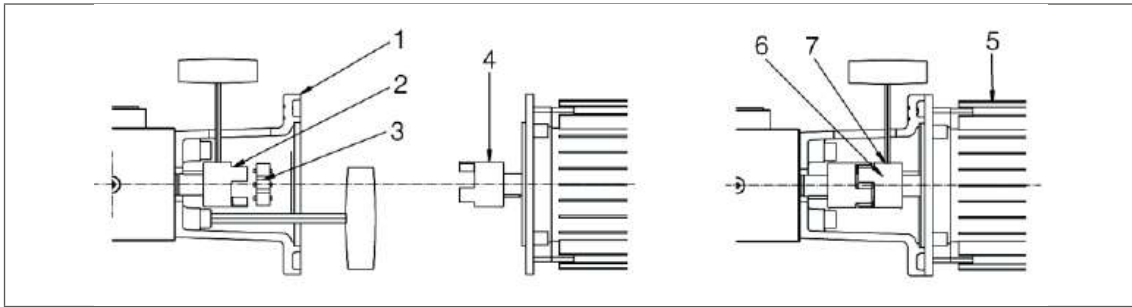

Fig. 13: Motor assembly

1. Fit the motor flange (1) to the ZIMM Screw jack and screw tight.
2. Mount the coupling halves (2) on the gearbox shaft and fix them in place.
3. Attach the coupling star (3).
4. Fit the coupling halves (4) on the motor side onto the motor shaft.
5. Fit the motor (5) onto the motor flange and screw tight.
6. Mount the coupling halves (6) on the motor side as follows:
 - Push onto the coupling halves on the gearbox side, leaving 1 mm axial play.
 - Tighten with mounting screw (7).
 - If the coupling halves cannot be pushed onto the motor shaft:
Adjust the position before step 5 and tighten them.
7. Close the mounting opening in the motor flange with suitable covering materials.

6.4 Connecting electrical components



WARNING

Electric shock!

Death or serious injury due to electric shock.

→ Only have work on the electrical system carried out by a specialist.

→ Observe the basic rules:

- Deenergise the system.
- Secure against restarting.
- Ensure all phases are electrically dead.
- Earth and short-circuit the system.
- Cover any adjacent parts that are still live.

6.4.1 Motor

- ✓ Motor (if included in the scope of supply) is attached.
- 1. Open the motor terminal box. The terminal assignment can be found in the terminal box of the motor.
- 2. Connect the motor according to the wiring diagram.

6.4.2 Limit switch

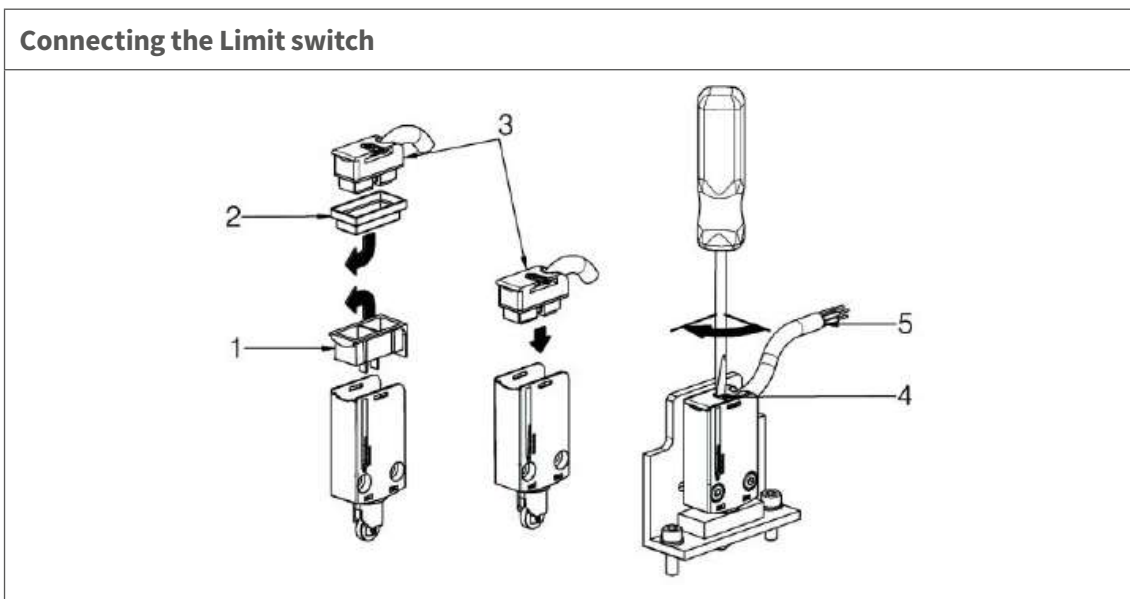
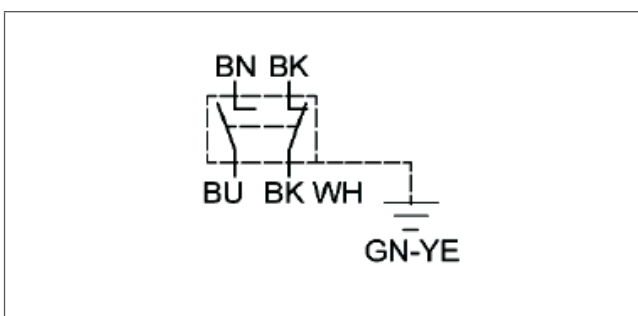

Fig. 14: Fitting the connector plug to the Limit switch

1. Remove the protective element (1) from the Limit switch.
2. Remove the protective element (2) from the connector plug.
3. Insert the connector plug (3) into the Limit switch.
4. Turn the screw (4) clockwise by 90°.
5. Connect the cable ends (5) as shown in the diagram (see Fig. 15).



BN Brown
BK Black
BU Blue
BK-WH Black and white
GN-YE Green-Yellow

Fig. 15: Electrical connection diagram for Limit switch

Rotate cable outlet If required, the cable outlet can be rotated by 180°.

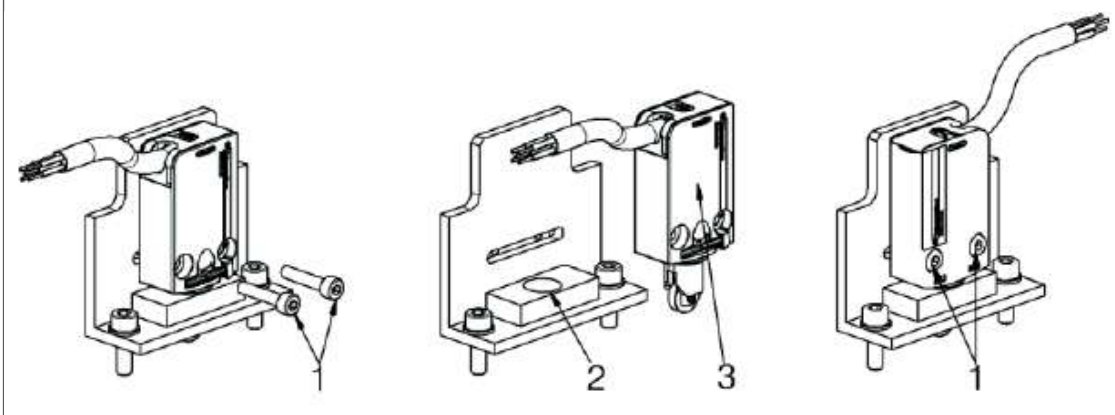

Fig. 16: Turning the cable outlet of the Limit switch

1. Loosen and remove the screws (1).
2. Pull the Limit switch (3) out of the holder (2) and turn it 180°.
3. Replace the Limit switch in the holder (2).
4. Refit and tighten the screws (1).

Adjusting the position of the Limit switch

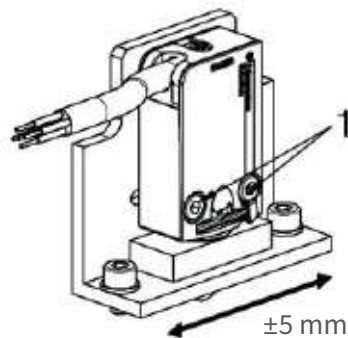

Fig. 17: Adjusting the Limit switch

1. Move the screw jack away from the limit switch trigger point.
2. Loosen the screws (1).
3. Fine-tune the Limit switch by moving it in the direction of the arrow.
4. Tighten the screws (1).

6.5 Test run

- ✓ System installed and aligned.
- ✓ Lubricated spindle (for more information, see chapter „7.2 Lubrication“, page 27).



CAUTION

Lateral forces due to incorrect alignment!

Damage to the gearbox and spindle.

1. If the alignment is incorrect: Correct the alignment, see chapter 6.6, page 22.
2. Repeat the test run.

High forces are generated!

Damage to the ZIMM Screw jack.

- Ensure that the Limit switches (optional) or end positions are not overrun.
- Ensure that attachments do not collide with other components.

- Run the screw jack over the complete travel in both directions.
When doing this, comply with the following:
 - Run the screw jack slowly and carefully.
 - If possible, drive through with little or no load.
 - Current consumption in the normal range and constant.
Strong fluctuations indicate misalignment and tension.
 - Monitor the temperature and avoid overheating, especially with long strokes and several strokes in succession.
 - Prevent Limit switches (optional) or end positions from being overrun.

6.6 Correcting the alignment

The alignment can be corrected with little effort if necessary.

- ✓ Lubricated spindle (for more information, see chapter „7.2 Lubrication“, page 27).

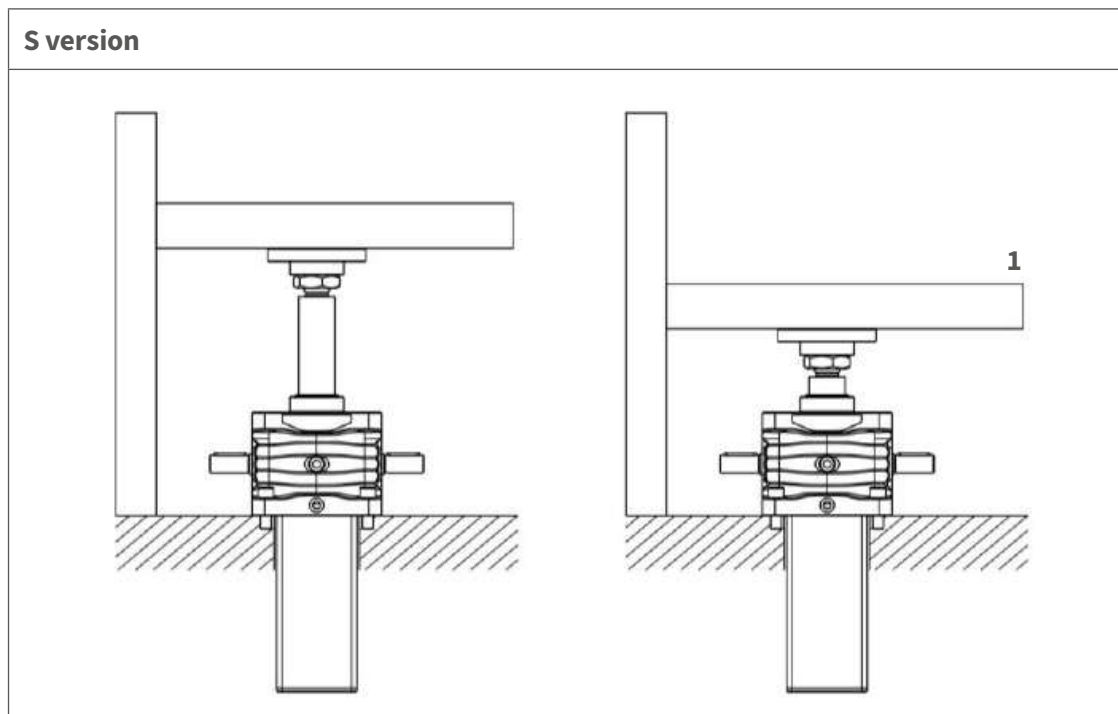

Fig. 18: Correctly aligned screw jack jack - S version

1. Loosen the fastening screws on the gearbox housing and on the spindle end.
2. Fully retract the jack (1).
3. Tighten the fastening screws.
4. Repeat the test run (see chapter „6.5 Test run“, page 21).

R version

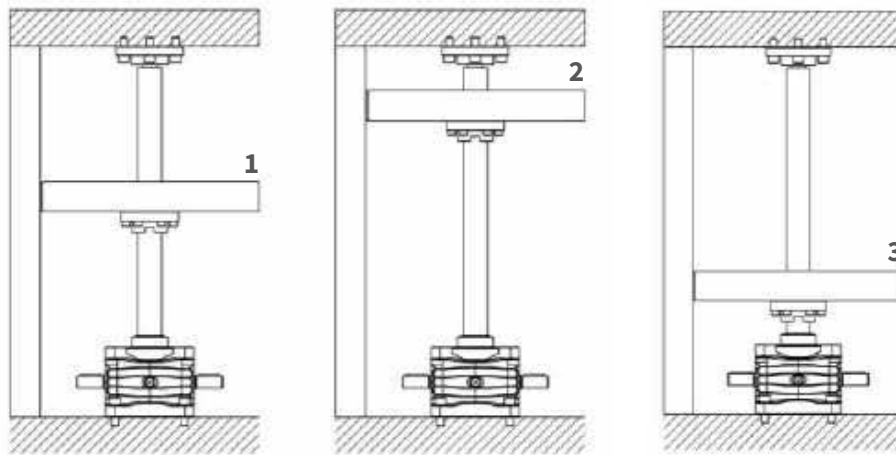

Fig. 19: Correctly aligned screw jack R version

1. Move to the middle position (1).
2. Loosen the fastening screws on the gearbox housing and on the bearing plate GLP.
3. Extend the nut to just before the end bearing plate (2).
4. Tighten the fastening screws of the bearing plate.
5. Retract to just before the gearbox (3).
6. Tighten the fastening screws on the gearbox housing.
7. Repeat the test run (see chapter „6.5 Test run“, page 21).

6.7 Commissioning

- ✓ ZIMM Screw jacks and attachments installed and connected.
- ✓ Lubricated spindle (for more information, see chapter „7.2 Lubrication“, page 27).
- ✓ Test run successfully completed.

CAUTION

High forces are generated!

Damage to the ZIMM Screw jack.

- Ensure that the Limit switches (optional) or end positions are not overrun.
- Ensure that attachments do not collide with other components.

1. Check all screw connections again.
2. Carry out a test run with operating load.
Pay attention to the following:
 - Torque is constant.
 - Current consumption is constant.
 - Operating temperature is within the normal range.
 - Limit switches (if present) or end positions are not overrun.
3. Regreasing the spindle under medium load after the first 2 hours of operation.
4. If a safety catch nut SIFA is fitted. Measure dimension „A“ and make a note of it (see Fig. 20). This dimension in new condition serves as a reference dimension in the further course of operation and is necessary to be able to assess wear later (see chapter 7.1.1., page 25)

6.8 Run-in phase

The run-in phase of the ZIMM gearbox and spindle usually lasts between 20 and 50 operating hours. During this time, a higher torque and a higher operating temperature must be expected.

The torque can be up to 50% higher than in operation after the running-in phase.

7 Operation and maintenance



WARNING

Lifting movement in the danger zone!

Serious injury or death.

→ Leave the danger zone and secure it.

7.1 Inspection

ZIMM Screw jacks must be inspected regularly to ensure trouble-free operation:

- First inspection after 1 month at the latest
 - Further inspections at least once a year
 - 1. Record inspections, for template see „Annex: Inspection log“, page 37.
 - 2. If necessary, carry out troubleshooting, see chapter 7.3, page 33.
 - 3. The inspection intervals must be adapted to the operating conditions and external influences.
- If problems cannot be localized and rectified:
Contact ZIMM GmbH.

7.1.1 Optical inspection

- ✓ Machine switched off and secured against being switched on again.
- 1. Check the lubrication of the spindle, grease if necessary and adjust the maintenance interval.
- 2. Check the screws for fastenings and couplings / connecting shafts and tighten if necessary.
- 3. If a safety catch nut SIFA is fitted: check wear as shown in Fig. 20.
 - Note dimension „A“ and compare it with the set value.
(see chapter 6.7 Commissioning, page 23):
 - $\text{Wear} = (\text{dimension „A“ in new condition}) - (\text{current dimension „A“})$.
 - Maximum permissible wear: 25% of the thread pitch.

Gearbox or spindle [TrØxP]	Thread pitch P [mm]	Max. permissible wear/thread play (25% of P) [mm]
Tr16x4, Tr18x4, Tr20x4	4	1,0
Tr30x6	6	1,5
Tr40x7	7	1,75
Tr50x8	8	2,0
Tr55x9, Tr60x9	9	2,25
Tr70x12	12	3
Tr80x16, Tr100x16, Tr120x16	16	4,0
Tr140x20, Tr160x20	20	5,0

- If the maximum permissible wear is exceeded, the support nut or gearbox must be replaced.
- Manual testing of dimension „A“ can be omitted with electrical monitoring of wear.

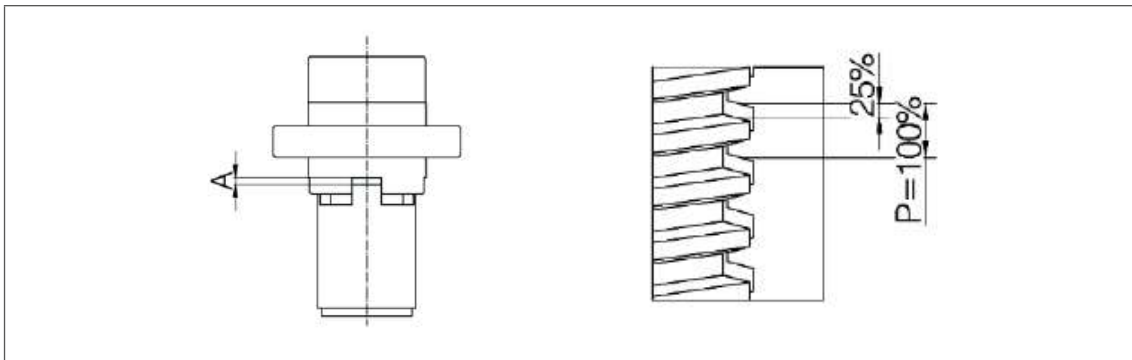

Fig. 20: Safety catch nut SIFA: Dimension „A“ for comparison during wear test

4. Check the clutch spiders visually.
5. Check coatings and surface coatings: repair any existing coating and paint damage or renew the surface protection.
6. Check the bellows:
 - Remove swarf and other coarse foreign objects
 - Replace worn, damaged or perforated elements
7. Clean the coil spring covers regularly and treat them with wet spray oil. Do not use viscous, resinifying oils!

8. Run the machine, paying attention to the following:
- Smooth and vibration-free operation
 - No excessive noise development
 - Consistent power consumption
 - Temperature rise within the permissible range

7.2 Lubrication

Good lubrication and the right lubricant are crucial for the function and service life of the ZIMM Screw jack.

Each application of ZIMM Screw jacks has different requirements, therefore the following chapters only contain recommendations.

NOTE

ZIMM standard greases are not hazardous goods.

→ Contact ZIMM for safety data sheets.

7.2.1 Lubricating the stroke gearbox

ZIMM Screw jacks of the ZE, Z and GSZ series are sealed and filled with high-quality synthetic fluid grease, for sizes 250 kN and above and the ZE-H series with synthetic oil.

Under normal conditions, the gearbox is lubricated for life.

7.2.2 Lubricating the bevel gearbox

The Bevel gear drives are filled with a synthetic oil and lubricated for life under normal conditions.

7.2.3 Lubricating the spindle with trapezoidal screw jack TR

Quantities for Lubricating new trapezoidal threaded spindles TR:

TR Ø (mm)	16	18	20	30	40	50	55	60	70	80	100	120	140	160
Quantity (ml/m)	24	27	30	45	60	75	83	90	105	120	150	180	210	240

NOTE

Less grease is required.

→ Use less lubricant when greasing.

Intervals

The spindle with trapezoidal screw jack must be lubricated regularly and as required.

Process	Interval
Regreasing the spindle	Every 500 double strokes
Clean the spindle and regrease it	In case of soiling
	Annually in normal operation
	Every 2 years in clean facilities

NOTE

Lubricating interval depends on the application.

→ Observe lubrication condition and set interval.



Lubricants

Standard grease for all series except ZE-H up to size 200 kN:

Order no.: Castrol Tribol GR 4020/460-2 PD,

Cartridge 400 ml

Standard grease for ZE-H series: Tungaloy BS1

Standard grease for sizes 250 kN and above:

Order no.: Castrol Tribol GR 3020/1000-2 PD,

cartridge 400 ml

Prerequisites

✓ When changing the lubricant: Spindle is clean.



WARNING

Movement in the lifting range!

Death, serious injury and risk of crushing.

- When lubricating with a grease gun, ensure that there is sufficient Freedom of movement over the entire stroke length.
- If Freedom of movement is not available:
 - Switch off the entire system and secure it against being switched on again.
 - Perform lubrication while stationary.
 - For greasing when installed, move the nut successively to several positions, so that the spindle is evenly greased.



CAUTION

Unsuitable lubricant!

Damage to the spindle.

- Do not use multi-purpose greases.
- Do not mix greases.
- When changing the lubricant: Clean the spindle, then relubricate.
- Use special grease if necessary.
- Only use lubricants that have been approved by ZIMM GmbH.
- ZIMM will be pleased to give you advice.

1. Remove the protective cap from the grease nipple.
2. Press the grease gun connection onto the grease nipple.
 - S version: grease nipple on the gearbox housing
 - R version: grease nipple on the travelling nut (optional)

3. Fill with lubricant:

When extending

- If personal safety is guaranteed: Perform lubrication when extending to ensure best lubricant distribution.
- To do this, extend slowly and apply strokes of the grease gun. Ensure the correct amount of lubricant is used.

When stationary

- If possible, lubricate in different stroke positions to ensure good lubricant distribution.
- S version: Only use small amounts of lubricant for each jack position, so that the lubricant is not pressed into the gearbox through the seals.
- R version: If no grease nipple is available, apply lubricant directly to the spindle.

NOTE

Easy lubrication during operation.

The **Z-LUB** automatic lubricator ensures optimum distribution of the lubricant.

→ Use the **Z-LUB** automatic lubricator instead of a grease gun.

→ ZIMM will be pleased to give you advice.

There are also different lubricants for different applications.

- High temperature
- Low temperature
- Food industry
- Heavy-duty applications
- etc.

→ ZIMM will be pleased to give you advice.

7.2.4 Pendulum nut PM Lubricating

Quantities for lubricating new self-aligning nuts (fill up lubrication channel):

Size PM	ZE-5	ZE-10	ZE-25	ZE-35/50	ZE-100	ZE-150	ZE-250	ZE-350
Quantity (ml)	4	5	8	18	80	90	95	180

For elubrication of the self-aligning nut, see chapter 7.2.3, page 28

7.2.5 Lubricating the spindle with ball screw drive KGT

The values in the following table [ml] can be used as guide values for lubricating ungreased KGT nuts in rotating versions:

Gradient	KGT-Ø										
	16	25	32	40	50	63	80	100	125	140	160
5	1	2	3	4							
10	2	4	8	15	20	40	60				
20			12	20	40	60	160	175			
25		7							300	400	500
40			23	40	60	100	210	250	500	550	650
50		14			75						
60						110	230	300	600	650	800
80								500	1000	1100	1300

Intervals

Process	Interval
Regreasing the spindle	At high load: after 100 hours (effective)
	With normal to low load: after 300 hours (effective)
Cleaning and greasing the spindle	In case of soiling

NOTE

Lubricating interval depends on the application.

→ Observe lubrication condition and set interval.



Lubricants

Standard grease for ball screw drive KGT

Order no.: Castrol Tribol GR 4747/220-2 HT, 400 ml cartridge
Quantity (guide value):

- 1 ml per 1 cm spindle diameter.

Prerequisites

- ✓ When changing the lubricant: Spindle is clean.



WARNING

Movement in the lifting range!

Death, serious injury and risk of crushing.

- When lubricating with a grease gun, ensure that there is sufficient Freedom of movement over the entire stroke length.
- If Freedom of movement is not available:
 - Switch off the entire system and secure it against being switched on again.
 - Perform lubrication while stationary.
 - For greasing when installed, move the nut successively to several positions, so that the spindle is evenly greased.



CAUTION

Unsuitable lubricant!

Damage to the spindle.

- Do not use multi-purpose greases.
- Do not mix greases.
- When changing the lubricant: Clean the spindle, then relubricate.
- Use special grease if necessary.
- Only use lubricants that have been approved by ZIMM GmbH.
- ZIMM will be pleased to give you advice.

1. Remove the protective cap from the grease nipple.
2. Press the grease gun connection onto the grease nipple:
 - S version: grease nipple on the gearbox housing.
 - R version: grease nipple on the travelling nut.
3. Fill with lubricant:

When extending

- If personal safety is guaranteed: Perform lubrication when extending to ensure best lubricant distribution.
- To do this, extend slowly and apply strokes of the grease gun. Ensure the correct amount of lubricant is used.

When stationary

- If possible, lubricate in different stroke positions to ensure good lubricant distribution.
- S version: Only use small amounts of lubricant for each jack position, so that the lubricant is not pressed into the gearbox through the seals.

NOTE

There are also different lubricants for different applications.

- Clean room
- Vacuum
- Food industry
- etc.

→ ZIMM will be pleased to give you advice.

7.3 Troubleshooting

If faults are identified, they can be isolated according to certain criteria and rectified with the appropriate measures.

The following table should help you to find approaches for troubleshooting.

Error	Possible cause	Measure
Spindle squeaks or vibrates	Incorrect spindle grease, stick-slip	→ Use a different grease: <ul style="list-style-type: none">• with high viscosity base oil• with additives• possibly with solid lubricants → ZIMM will be pleased to give you advice.
	Geometric errors in the system	→ Check alignment: <ul style="list-style-type: none">• Parallelism of the spindles to each other• Parallelism of the spindles to the guides• Angularity of the mounting surfaces (gearbox, nut, fixing flanges, etc.)
	Long, thin spindle	→ If possible, additionally support or store the spindle. → Reinforce the design.

Spindle squeaks or vibrates	Temperature of the spindle too high (>approx. 90 °C)	<ol style="list-style-type: none"> 1. Check operating parameters. 2. Reduce duty cycle or load. → ZIMM will be pleased to give you advice.
	Unfavorable spindle frequency	→ Change speed: slower or faster (observe limit values)
	Load too high	→ Reduce the load during the running-in phase.
	Vibrations are transmitted to the system	→ Fit a plastic or rubber pad under the travelling nut (for R version).
High wear on the trapezoidal thread	Spindle is dirty	<ol style="list-style-type: none"> 1. Clean the spindle and regrease it. 2. Shorten the greasing intervals.
	Incorrect spindle grease	<ol style="list-style-type: none"> 1. Check spindle grease, ZIMM will be pleased to give you advice (load, speed, etc.). 2. Clean the spindle and regrease it if necessary.
	Lack of lubricant	<ol style="list-style-type: none"> 1. Clean the spindle and regrease it if necessary. 2. Shorten the greasing intervals.
	Geometric errors in the system	→ Check alignment: <ul style="list-style-type: none"> • Parallelism of the spindles to each other • Parallelism of the spindles to the guides • Angularity of the mounting surfaces (gearbox, nut, fixing flanges, etc.)
	Load too high	→ Contact ZIMM (load, speed, duty cycle, etc.).
Operating temperature too high	Load or duty cycle too high	→ Check the operating parameters, ZIMM will be pleased to give you advice.
	Geometric errors in the system	→ Check alignment: <ul style="list-style-type: none"> • Parallelism of the spindles to each other • Parallelism of the spindles to the guides • Angularity of the mounting surfaces (gearbox, nut, fixing flanges, etc.)
	Incorrect spindle grease	<ol style="list-style-type: none"> 1. Check spindle grease, ZIMM will be pleased to give you advice (load, speed, etc.). 2. Clean the spindle and regrease it if necessary.
Noise at Coupling or connecting shaft	Friction in the coupling star	→ Lubricate the coupling star with Vaseline or plastic-compatible grease.
	Permissible offset exceeded	→ Check and correct alignment.
Slight leakage at the shaft seal	Slight leakage	A slight leakage is normal and not a technical problem. → Wipe off the leak and continue to monitor it.
Gross leakage	Shaft sealing ring defective or excessive pressure in the gearbox	→ Contact ZIMM and send photos.

8 Decommissioning and recommissioning

Decommissioning

CAUTION

Corrosion!

Damage to the ZIMM Screw jack due to prolonged standstill.

→ Oil bare areas and grease the spindle.

Recommissioning

After a longer downtime of the ZIMM Screw jack:

1. Clean the spindle and
2. Lubricating the spindle again, see chapter „7.2 Lubrication“, page 27.

9 Repair and replacement

NOTE

The warranty is void if the ZIMM Screw jack is disassembled.

→ ZIMM Screw jacks may only be disassembled by ZIMM or by personnel authorized by ZIMM.

→ Get in touch with ZIMM GmbH.

10 Waste disposal

The ZIMM Screw jack complies with the current standards and guidelines for the disposal of old appliances and does not contain any toxic substances that require special precautions.

→ During disposal, ensure:

- Compliance with regional laws and regulations on waste disposal
- Professional disposal and recycling by a professional waste disposal company

The following materials are available for disposal:

- Lubricants (grease or oil in the gearbox, grease on the spindle)
- Steel parts (with environmentally friendly paints or coatings)
- Anodized aluminium (components)
- Bronze / copper (Bevel gear, nuts or coils of the motor)
- Plastic parts (seals etc.)

11 Declaration of incorporation

ZIMM GmbH

Millennium Park 3 | 6890 Lustenau | Austria
T: +43 (0) 5577/806-0 | F: +43 (0) 5577/806-8
E-Mail: info@zimm.com | www.zimm.com



Declaration of incorporation

for partly completed machinery

(Described in EC Machinery Directive 2006/42/EC, Annex II B)

The manufacturer "ZIMM GmbH" declares herewith that all "screw jacks" delivered by ZIMM of the models SHZ, MSZ, Z, GSZ or ZE

Size (max. load)

02 (0,25 kN)
2 (2,5 kN)
5 (5 kN)
10 (10 kN)
25 (25 kN)
35 (35 kN)
50 (50 kN)
100 (100 kN)
150 (150 kN)
200 (200 kN)
250 (250 kN)
350 (350 kN)
500 (500 kN)
650 (650 kN)
750 (750 kN)
1000 (1000 kN)

including the attachments described in the ZIMM engineering catalogue valid at the time of delivery

conform with the following essential requirements of the **Machinery Directive 2006/42/EC**:

Annex I, Article 1.3.3, 1.1.5, 1.3.4 and 4.1.2.3

In addition we declare that the relevant technical documentation for this partly completed machinery was prepared in accordance with Annex VII, part B, and undertake to transmit these to the market oversight authorities upon request. Authorised representative for the compilation of the relevant technical documentation:

ZIMM GmbH, AT-6890 Lustenau, Millennium Park 3

Putting the partly completed machinery into service is prohibited until the partly completed machinery has been incorporated into final machinery which conforms to the provisions of the EC Machinery Directive and there is an EC Declaration of Conformity in accordance with Annex II A.

Enclosure: current assembly instructions

ZIMM GmbH
Millennium Park 3
AT-6890 Lustenau, 28th August 2019

Gunther Zimmermann, CEO

A: Raiffeisenlandesbank Bregenz
Kontonr. 11999 | BLZ 37000
IBAN: AT40 3700 0000 0001 1999
BIC: RVVGAT2B

CH: BTV Staad
IBAN CHF: CH38 0852 5000 SA31 733A A
IBAN EUR: CH11 0852 5000 SA31 733A B
BIC: BTVACH22

FN 61869 i | Feldkirch
ATU 69063247
ARA-Lizenznr. 4334

ZIMM GmbH
Millennium Park 3 | info@zimm.com
A-6890 Lustenau | +43(0)5577 806-0

